

# FR8012HAQ Datasheet

Bluetooth Low Energy SOC with SIG Mesh integrated

---

Version: V1.2

Release Date:2021.12

---

## Table of Contents

DESCRIPTION .....	3
FEATURES .....	3
APPLICATIONS.....	3
ORDERING INFORMATION .....	3
1. Hardware Details.....	4
1.1 Block Diagram .....	4
1.2 Bluetooth Radio.....	4
1.3 Bluetooth Controller .....	5
1.4 Peripheral Interfaces .....	5
1.5 Integrated Power Control and Regulation .....	5
1.6 Battery Charger .....	5
2. Package and Pin Information.....	6
2.1 Package.....	6
2.2 Package Physical Dimensions .....	6
2.3 Pins Description .....	7
2.4 Application circuit .....	9
3. Electrical Characteristics.....	10
3.1 Absolute Maximum Ratings.....	10
3.2 Recommended Operating Conditions .....	10
3.3 Power Consumption.....	10
3.4 Crystal oscillator .....	11
Contact Information .....	12
Revision History .....	12

## DESCRIPTION

FR8012HA is a SOC (system on chip) for rapid development of Bluetooth Low Energy related products. It contains Bluetooth V5.0 (LE Mode) fully compliant system with Freqchip designed firmware and software stack. Users can develop various applications based on embedded 32-bits high performance MCU.

With Freqchip's innovational technology, FR8012H integrates, PMU (Li-battery charger + LDO) , SPI flashROM with XIP mode, IIC, UART, GPIO, ADC, PWM all in a single chip, which provides customer with:

1. competitive power consumption
2. stable connection
3. low-cost BOM

The Bluetooth Smart firmware includes the L2CAP service layer protocols, Security Manager (SM), Attribute Protocol (ATT), the Generic Attribute Profile (GATT) and the Generic Access Profile (GAP). Furthermore, application profiles such as Proximity, Health Thermometer, Heart Rate, Blood Pressure, Glucose, Human Interface Device (HID) and SDK (include drivers, OS API, etc. ) are supported. The SDK has integrated SIG Mesh for networking application.

## FEATURES

- Compliant with Bluetooth Specification V5.0 LE, support 2M, 1M, 500K and 125K data rate
- Embedded 32-bitsProcessor
  - 12~48Mhz speed

- Internal mask 150KB ROM, up to 48KB SRAM
- Internal 4M Flash ROM for user space software and data
- Integrated Battery Charger
- Integrated DC-DC Regulator
- Interface:
  - GPIO
  - UART
  - SPI
  - I2C
  - PWM
  - I2S
  - LED
- ROM Software:
  - BLE Profile & Protocol: GATT, LM, LC, etc.
  - Driver API
  - SIG Mesh

## APPLICATIONS

- smart toy
- led control
- SIG Mesh application
- smart locks
- etc.

## ORDERING INFORMATION

FR8012HAQ -40°C ~ +105°C  
 QFN32, 4.0\*4.0\*0.75, 0.4pitch

# 1. Hardware Details

## 1.1 Block Diagram

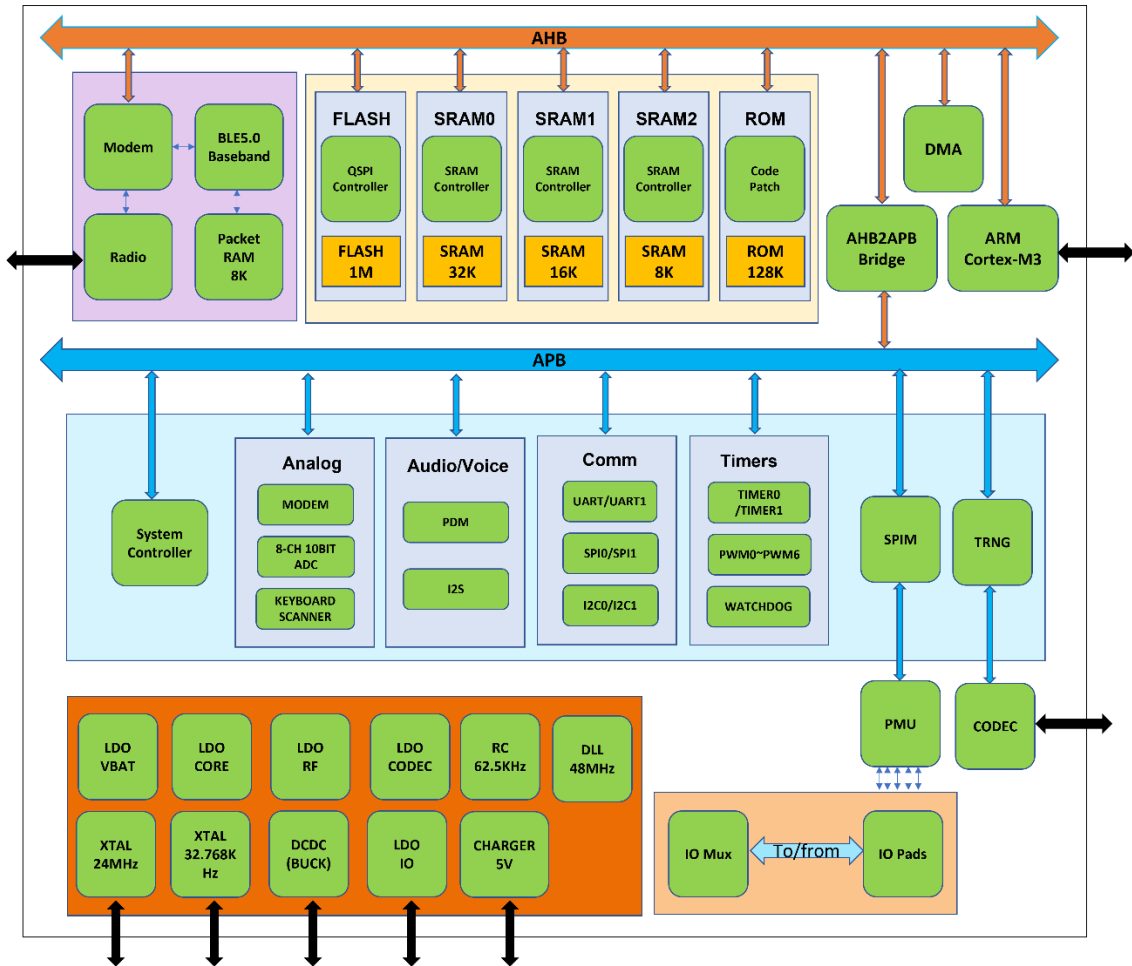

Figure 1-1 Functional Block Diagram

## 1.2 Bluetooth Radio

- On-chip balun (50Ω impedance in TX and RX modes)
- No external trimming is required in production
- Qualified to Bluetooth v5.0 LE specification
- Up to 10dBm RF transmit power
- -95dBm (1M) receiver sensitivity in LDO mode
- Integrated channel filters
- Digital demodulator for improved sensitivity and co-channel rejection
- Real time digitized RSSI
- Fast AGC for enhanced dynamic range

### 1.3 Bluetooth Controller

- All device classes support (Broadcaster, Central, Observer, Peripheral)
- All packet types (Advertising / Data / Control)
- Encryption (AES / CCM)
- Bit stream processing (CRC, Whitening)
- Frequency hopping calculation
- Low power modes supporting internal 32.0 kHz RC oscillator or external 32.768 kHz crystal (FR8018H only)
- Supports power down of the baseband during the protocol's idle periods

### 1.4 Peripheral Interfaces

- UART port for Debugging and AT Commands
- IIC interface to support external EEPROM or other devices (like G-SENSOR)
- One more SPI interface to support other device (like OLED controller)
- Up to 17 general purpose IOs (17 IOs can be set in interrupt mode)
- General purpose 10-bits ADC used for ADKey and other analog input
- PWM controller
- Hardware LED controller
- General purpose programmable timer for various task
- Watchdog used for tracking unexpected exception

### 1.5 Integrated Power Control and Regulation

- Embedded Power-On-Reset
- Low power 0.9v core voltage
- On-chip high efficiency switch-mode power supply, 1.8v to 4.3v input direct from battery and programmable output voltage
- On-chip Low Dropout (LDO) Linear Regulator for internal Digital, RF and Analog circuit
- Power management features include software shutdown and hardware wake-up
- Power-on-reset cell detects low supply voltage
- Internal voltage level detector

### 1.6 Battery Charger

- Lithium ion/Lithium polymer battery charger
- Embedded LVD(low voltage detect)
- Programmable charging current. Fast charging support up to 200mA with no external components

## 2. Package and Pin Information

### 2.1 Package

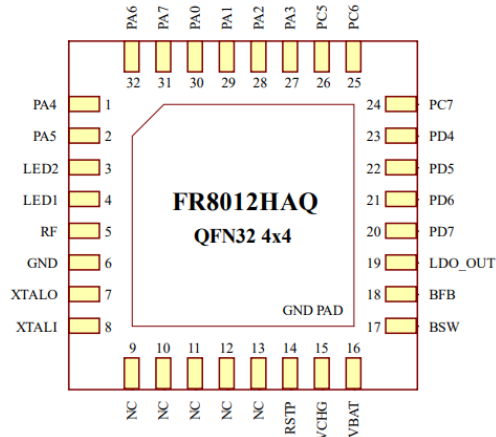

Figure 2-1 FR8012HAQ pin information

### 2.2 Package Physical Dimensions

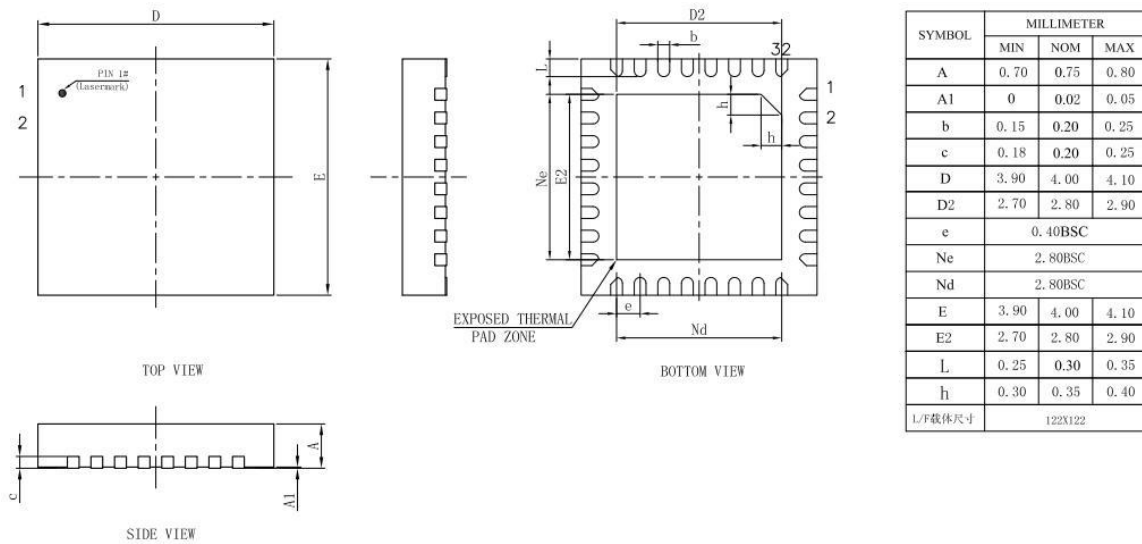

Figure 2-2 Package Physical Dimensions

## 2.3 Pins Description

FR8012HA is a CMOS device. Floating level on input signals will cause unstable device operation and abnormal current consumption. Pull-up or Pull-down resistors should be used appropriately for input or bidirectional pins.

Table 2-1 Pin Abbreviations

Notation	Description
I	Digital Input
O	Digital Output
AI	Analog input
AO	Analog output
IO	Bidirectional(digital)
OD	Open Drain
PWR	Power
GND	Ground

Table 2-2 pin description

Pin name	Pin#	Type	Description
PORTA4	1	I/O	PA4/SCL0/I2SCLK/PWM4/SSPCLK/URXD0/URXD1/CLKOUT/PDMCLK/PWM5
PORTA5	2	I/O	PA5/SDA0/I2SFRM/PWM5/SSPCSN/UTXD0/UTXD1/ANTCTL1/PDMDAT/PWM4
LED2	3	O	LED2 control output
LED1	4	O	LED1 control output
RF	5	AI/O	RF input and output
GND	6	GND	Ground
XTALO	7	AO	crystal oscillator output
XTALI	8	AI	crystal oscillator input
NC	9		
NC	10		
NC	11		
NC	12		
NC	13		
RSET	14	AI	Reset
VCHG	15	PWR	Power supply for charger

Pin name	Pin#	Type	Description
VBAT	16	PWR	Positive power supply for DC/DC
BSW	17	AO	DC/DC output terminal
BFB	18	AI	DC/DC feedback input terminal
LDO_OUT	19	AO	Analog linear regulator output
PORTD7	20	I/O	PD7/SDA1/I2SDIN/PWM1/SSPDIN/UTXD0/UTXD1/ANTCTL1/PDMDAT/PWM0/ADC3
PORTD6	21	I/O	PD6/SCL1/I2SDOUT/PWM0/SSPDOUT/URXD0/URXD1/CLKOUT/PDMCLK/PWM1/ADC2
PORTD5	22	I/O	PD5/SDA0/I2SFRM/PWM5/SSPCSN/UTXD0/UTXD1/ANTCTL0/PDMDAT/PWM4/ADC1
PORTD4	23	I/O	PD4/SCL0/I2SCLK/PWM4/SSPCLK/URXD0/URXD1/ANTCTL0/PDMCLK/PWM5/ADC0
PORTC7	24	I/O	PC7/SDA1/I2SDIN/PWM5/SSPDIN/UTXD0/UTXD1/SWDIO/PDMDAT/PWM4
PORTC6	25	I/O	PC6/SCL1/I2SDOUT/PWM4/SSPDOUT/URXD0/URXD1/SWTCK/PDMCLK/PWM5
PORTC5	26	I/O	PC5/SDA0/I2SFRM/PWM5/SSPCSN/UTXD0/UTXD1/SWV/PDMDAT/PWM4
PORTA3	27	I/O	PA3/SDA1/I2SDIN/PWM3/SSPDIN/UTXD0/UTXD1/ANTCTL1/PDMDAT/PWM2
PORTA2	28	I/O	PA2/SCL1/I2SDOUT/PWM2/SSPDOUT/URXD0/URXD1/ANTCTL0/PDMCLK/PWM3
PORTA1	29	I/O	PA1/SDA0/I2SFRM/PWM1/SSPCSN/UTXD0/UTXD1/ANTCTL0/PDMDAT/PWM0
PORTA0	30	I/O	PA0/SCL0/I2SCLK/PWM0/SSPCLK/URXD0/URXD1/CLKOUT/PDMCLK/PWM1
PORTA7	31	I/O	PA7/SDA1/I2SDIN/PWM1/SSPDIN/UTXD0/UTXD1/ANTCTL0/PDMDAT/PWM0
PORTA6	32	I/O	PA6/SCL1/I2SDOUT/PWM0/SSPDOUT/URXD0/URXD1/CLKOUT/PDMCLK/PWM1



## 2.4 Application circuit

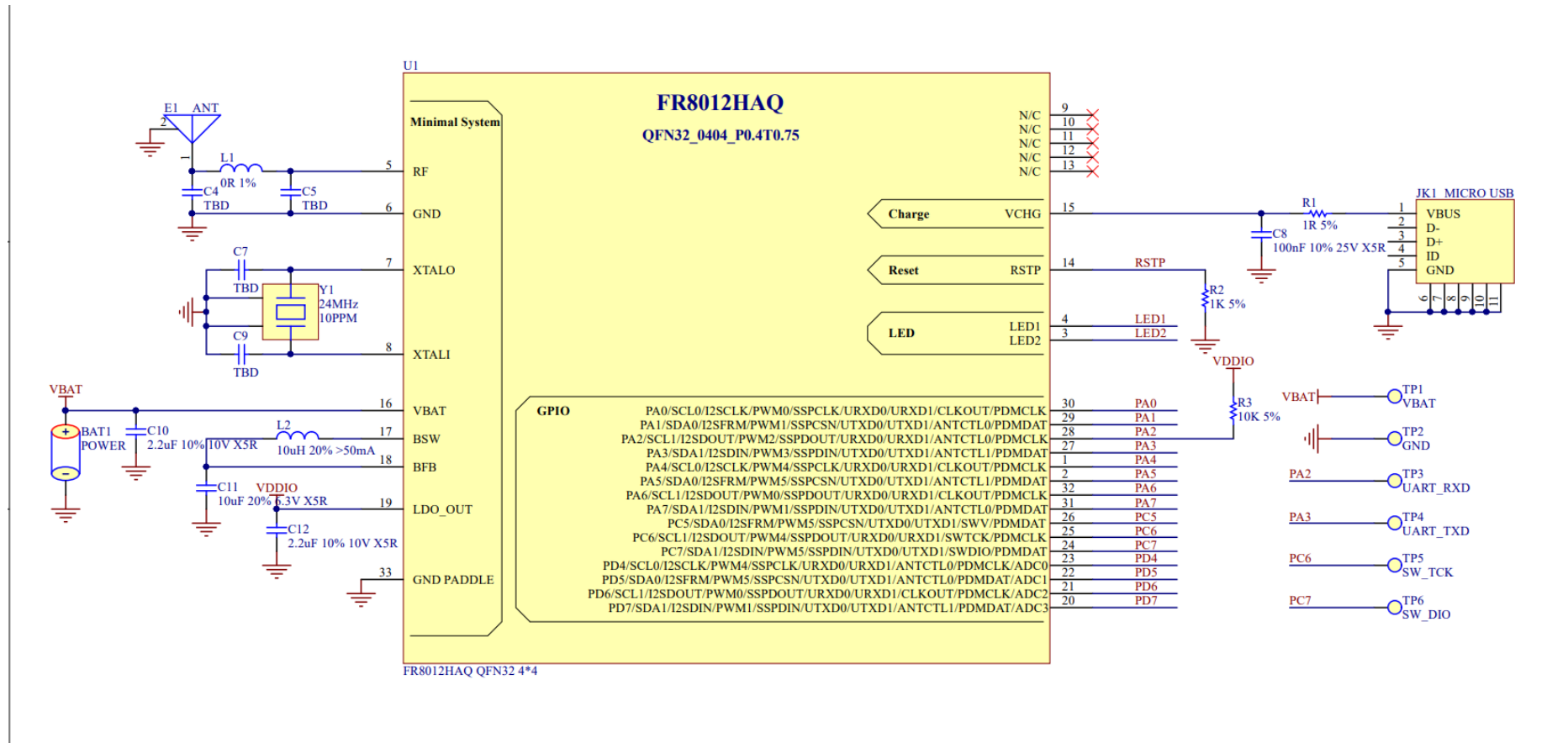

### 3. Electrical Characteristics

#### 3.1 Absolute Maximum Ratings

Continuous operation at or beyond these conditions may permanently damage the device.

Table 3-1 Absolute Maximum Ratings

Rating		Min	Max	Unit
Storage Temperature		-40	125	°C
Core Supply Voltage		0.9	1.3	V
I/O Voltage	ALDO_OUT	1.6	3.3	V
Supply Voltage	VBAT	1.8	4.3	V
	VCHG	4.75	5.25	V

#### 3.2 Recommended Operating Conditions

Table 3-2 Recommended Operating Conditions

Operating Condition		Min	Typ	Max	Unit
Operating Temperature Range		-40	20	105	°C
Core Supply Voltage		0.9	1.2	1.3	V
I/O Voltage	ALDO_OUT	1.6	2.9	3.3	V
Supply Voltage	VBAT	1.8	3.3	4.3	V
Charge input voltage	VCHG	4.75	5	5.25	V

#### 3.3 Power Consumption

Table 3-3 Power Consumption

Operation Mode	Average	Maximum	Unit
TX peek current (0dB)		8	mA
RX peek current		9.7	mA
Deep sleep current (include 48K retention RAM)	6.1		μA
Power off	2.7		μA

### 3.4 Crystal oscillator

Table 3-4 Crystal oscillator

CLOCK SOURCE	Min	Typ	Max	Unit
<b>Main Crystal OSC(12M/24Mhz) for Bluetooth RF application</b>				
Clock Frequency	24	24	24	MHz
Digital rim range		7.5		pf
Trim step size		0.1		pf
Tolerance		+10		ppm
Note: XTAL Load capacitance = 7.5pf				

## Contact Information

**Website:** [www.freqchip.com](http://www.freqchip.com)

**Sales Email:** [sales@freqchip.com](mailto:sales@freqchip.com)

**Phone:** +86-21-5027-0080

**Feedback:**

Freqchip welcomes feedback on this product and this document. If you have comments or suggestions, please send an email to [doc@freqchip.com](mailto:doc@freqchip.com)

## Revision History

**Feedback:**

Freqchip welcomes feedback on this product and this document. If you have comments or suggestions, please send an email to [docs@freqchip.com](mailto:docs@freqchip.com).

Reversion Number	Reversion Date	Description
V1.2	2021.12.23	Initial Draft